



## Features

- 650-Volt Schottky Rectifier
- Zero Reverse Recovery Current
- Zero Forward Recovery Voltage
- High-Frequency Operation
- Temperature-Independent Switching Behavior
- Extremely Fast Switching
- Positive Temperature Coefficient on  $V_F$

## Benefits

- Replace Bipolar with Unipolar Rectifiers
- Essentially No Switching Losses
- Higher Efficiency
- Reduction of Heat Sink Requirements
- Parallel Devices Without Thermal Runaway

## Applications

- Switch Mode Power Supplies (SMPS)
- Boost diodes in PFC or DC/DC stages
- Free Wheeling Diodes in Inverter stages
- AC/DC converters

| Part Number | Package  | Marking    |
|-------------|----------|------------|
| GC3D20065A  | TO-220-2 | GC3D20065A |

|                              |   |         |
|------------------------------|---|---------|
| $V_{RRM}$                    | = | 650 V   |
| $I_F(T_C=135^\circ\text{C})$ | = | 26 A**  |
| $Q_c$                        | = | 48 nC** |

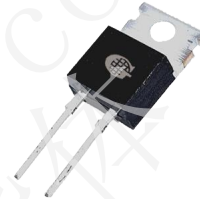

## Package

TO-220-2



## Maximum Ratings ( $T_C = 25^\circ\text{C}$ unless otherwise specified)

| Symbol         | Parameter                                      | Value                     | Unit             | Test Conditions   | Note   |
|----------------|--|---------------------------|------------------|---|--------|
| $V_{RRM}$      | Repetitive Peak Reverse Voltage                | 650                       | V                |   |        |
| $V_{RSM}$      | Surge Peak Reverse Voltage                     | 650                       | V                |   |        |
| $V_{DC}$       | DC Blocking Voltage                            | 650                       | V                |   |        |
| $I_F$          | Continuous Forward Current<br>(Per Leg/Device) | 27.5/55<br>13/26<br>10/20 | A                | $T_C=25^\circ\text{C}$<br>$T_C=135^\circ\text{C}$<br>$T_C=149^\circ\text{C}$  | Fig. 3 |
| $I_{FRM}$      | Repetitive Peak Forward Surge Current          | 46*<br>31*                | A                | $T_C=25^\circ\text{C}$ , $t_p = 10$ ms, Half Sine Wave<br>$T_C=110^\circ\text{C}$ , $t_p = 10$ ms, Half Sine Wave       |        |
| $I_{FSM}$      | Non-Repetitive Peak Forward Surge Current      | 90*<br>71*                | A                | $T_C=25^\circ\text{C}$ , $t_p = 10$ ms, Half Sine Wave<br>$T_C=110^\circ\text{C}$ , $t_p = 10$ ms, Half Sine Wave       | Fig. 8 |
| $I_{FSM}$      | Non-Repetitive Peak Forward Surge Current      | 860*<br>680*              | A                | $T_C=25^\circ\text{C}$ , $t_p = 10$ $\mu\text{s}$ , Pulse<br>$T_C=110^\circ\text{C}$ , $t_p = 10$ $\mu\text{s}$ , Pulse | Fig. 8 |
| $P_{tot}$      | Power Dissipation (Per Leg/Device)             | 136.5<br>59               | W                | $T_C=25^\circ\text{C}$<br>$T_C=110^\circ\text{C}$   | Fig. 4 |
| dV/dt          | Diode dV/dt ruggedness                         | 200                       | V/ns             | $V_R=0-650\text{V}$   |        |
| $T_J, T_{stg}$ | Operating Junction and Storage Temperature     | -55 to<br>+175            | $^\circ\text{C}$ |   |        |
|                | TO-247 Mounting Torque                         | 1<br>8.8                  | Nm<br>lbf-in     | M3 Screw<br>6-32 Screw  |        |

\* Per Leg, \*\* Per Device

### Electrical Characteristics (Per Leg)

| Symbol | Parameter                 | Typ.              | Max.       | Unit          | Test Conditions  | Note   |
|--------|---------------------------|-------------------|------------|---------------|--|--------|
| $V_F$  | Forward Voltage           | 1.5<br>2.0        | 1.8<br>2.4 | V             | $I_F = 10\text{ A}$ $T_J = 25^\circ\text{C}$<br>$I_F = 10\text{ A}$ $T_J = 175^\circ\text{C}$  | Fig. 1 |
| $I_R$  | Reverse Current           | 12<br>24          | 60<br>220  | $\mu\text{A}$ | $V_R = 650\text{ V}$ $T_J = 25^\circ\text{C}$<br>$V_R = 650\text{ V}$ $T_J = 175^\circ\text{C}$  | Fig. 2 |
| $Q_C$  | Total Capacitive Charge   | 24                |            | nC            | $V_R = 400\text{ V}$ , $I_F = 10\text{ A}$<br>$di/dt = 500\text{ A}/\mu\text{s}$<br>$T_J = 25^\circ\text{C}$   | Fig. 5 |
| C      | Total Capacitance         | 460.5<br>44<br>40 |            | pF            | $V_R = 0\text{ V}$ , $T_J = 25^\circ\text{C}$ , $f = 1\text{ MHz}$<br>$V_R = 200\text{ V}$ , $T_J = 25^\circ\text{C}$ , $f = 1\text{ MHz}$<br>$V_R = 400\text{ V}$ , $T_J = 25^\circ\text{C}$ , $f = 1\text{ MHz}$ | Fig. 6 |
| $E_C$  | Capacitance Stored Energy | 3.6               |            | $\mu\text{J}$ | $V_R = 400\text{ V}$   | Fig. 7 |

Note: This is a majority carrier diode, so there is no reverse recovery charge.

### Thermal Characteristics

| Symbol          | Parameter                                | Typ.           | Unit                      | Note   |
|-----------------|--|----------------|---------------------------|--------|
| $R_{\theta JC}$ | Thermal Resistance from Junction to Case | 1.3**<br>0.65* | $^\circ\text{C}/\text{W}$ | Fig. 9 |

\*\* Per Leg, \* Both Legs

### Typical Performance (Per Leg)

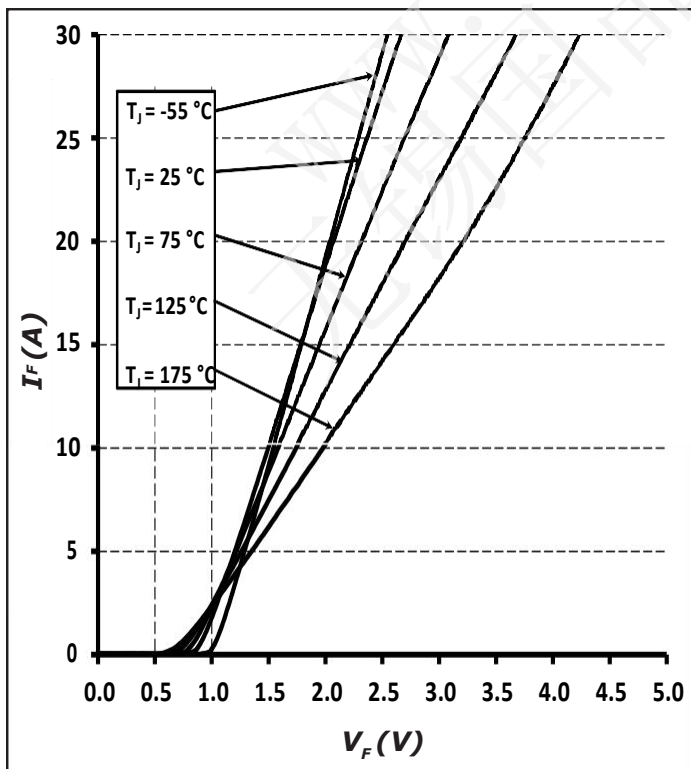

Figure 1. Forward Characteristics

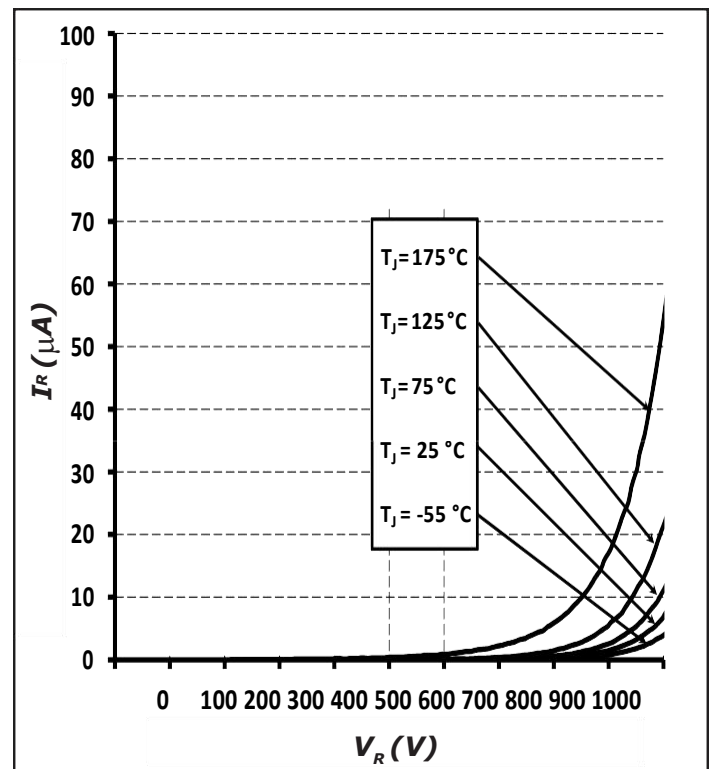

Figure 2. Reverse Characteristics

**Typical Performance (Per Leg)**

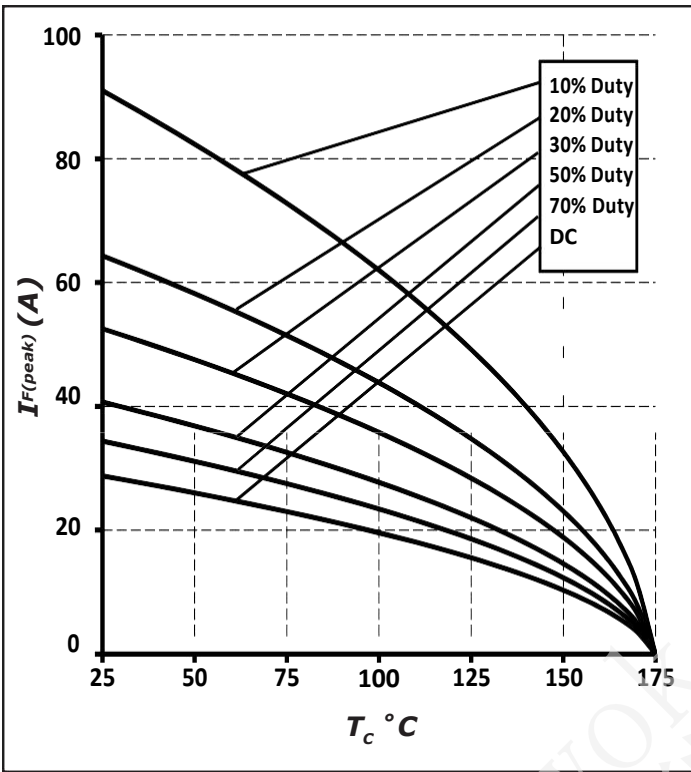

Figure 3. Current Derating

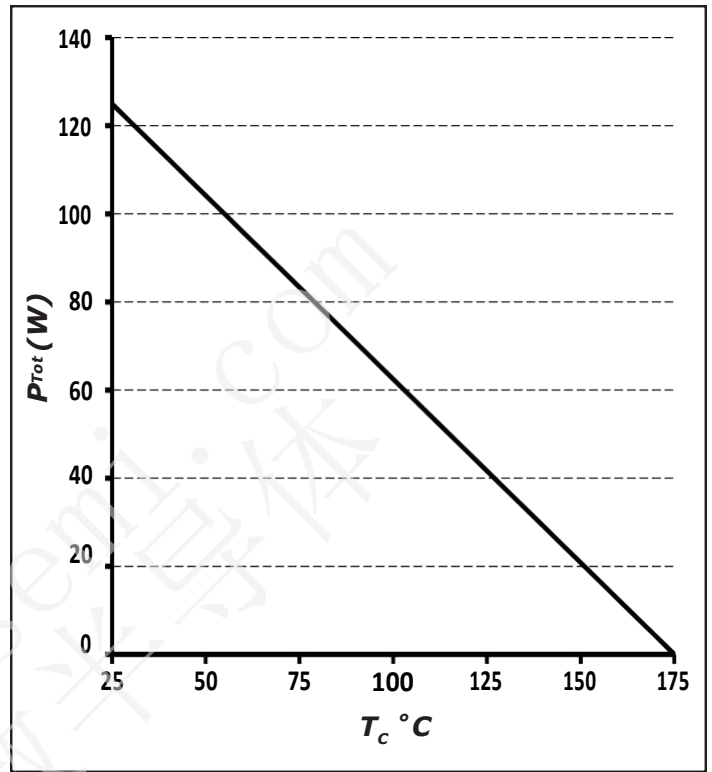

Figure 4. Power Derating

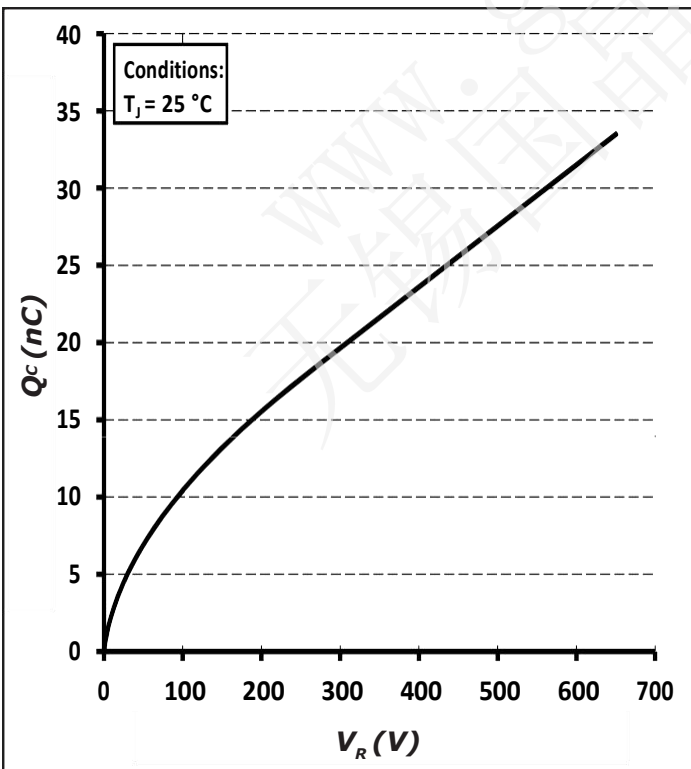

Figure 5. Total Capacitance Charge vs. Reverse Voltage

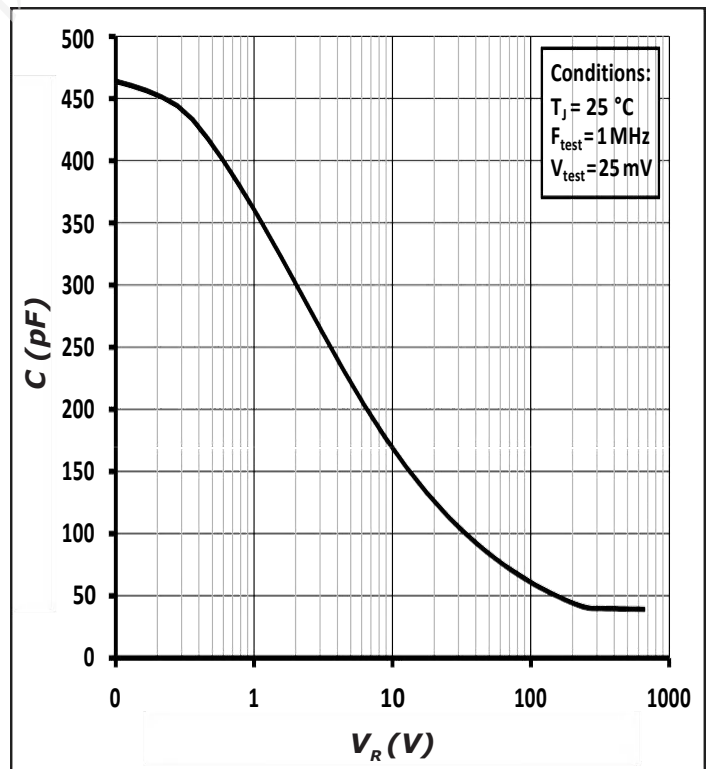

Figure 6. Capacitance vs. Reverse Voltage

Typical Performance

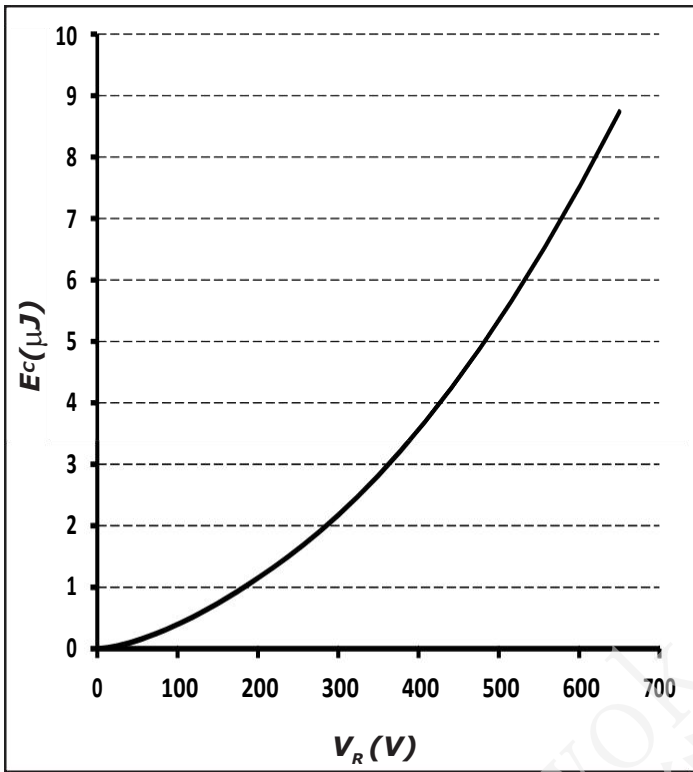

Figure 7. Capacitance Stored Energy

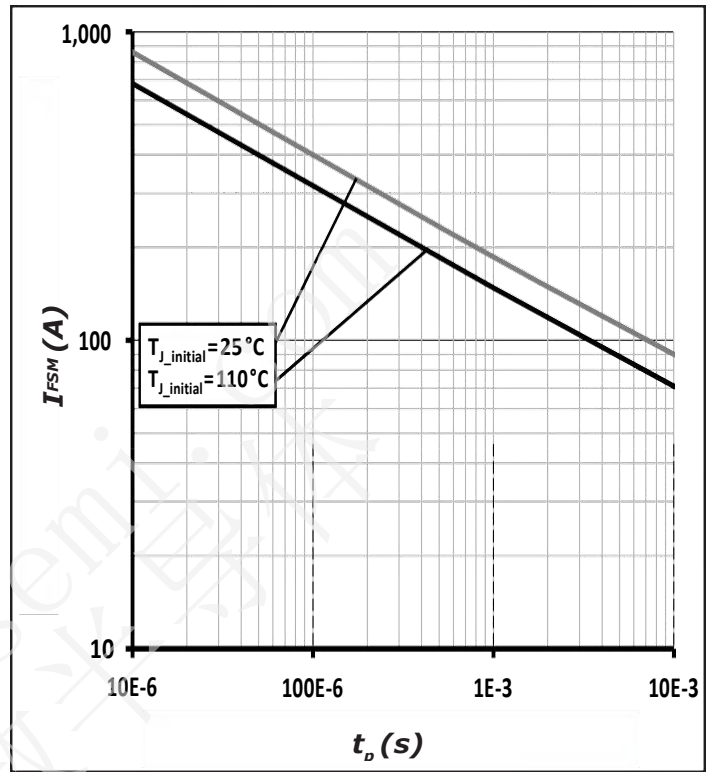

Figure 8. Non-repetitive peak forward surge current versus pulse duration (sinusoidal waveform)

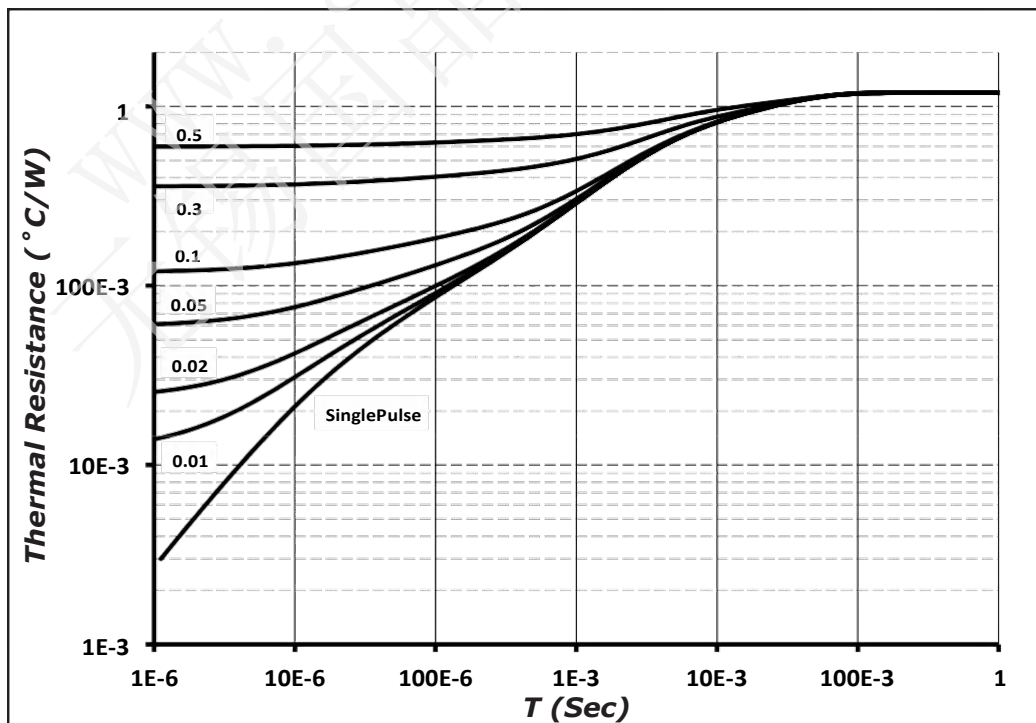
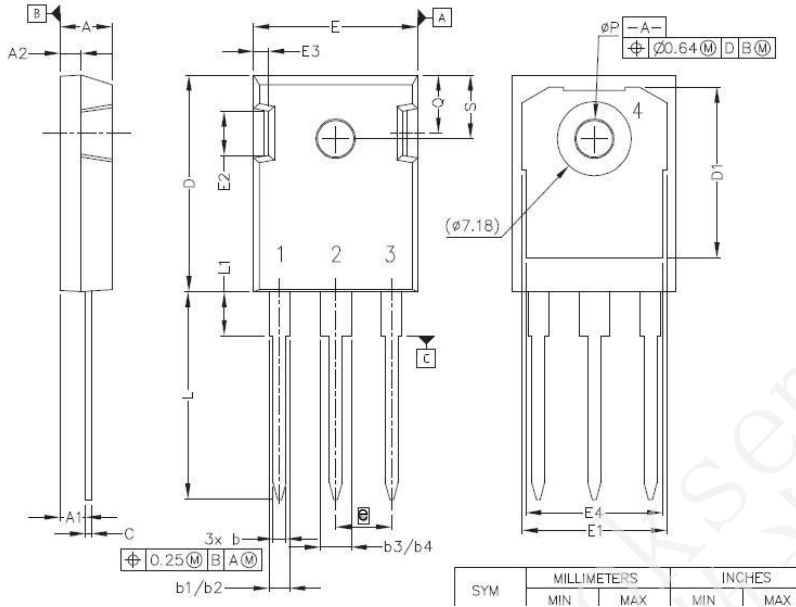

Figure 9. Transient Thermal Impedance

## Package Dimensions

Package TO-247-3



| POS | Inches   |      | Millimeters |       |
|-----|----------|------|-------------|-------|
|     | Min      | Max  | Min         | Max   |
| A   | .190     | .205 | 4.83        | 5.21  |
| A1  | .090     | .100 | 2.29        | 2.54  |
| A2  | .075     | .085 | 1.91        | 2.16  |
| b   | .042     | .052 | 1.07        | 1.33  |
| b1  | .075     | .095 | 1.91        | 2.41  |
| b2  | .075     | .085 | 1.91        | 2.16  |
| b3  | .113     | .133 | 2.87        | 3.38  |
| b4  | .113     | .123 | 2.87        | 3.13  |
| c   | .022     | .027 | 0.55        | 0.68  |
| D   | .819     | .831 | 20.80       | 21.10 |
| D1  | .640     | .695 | 16.25       | 17.65 |
| D2  | .037     | .049 | 0.95        | 1.25  |
| E   | .620     | .635 | 15.75       | 16.13 |
| E1  | .516     | .557 | 13.10       | 14.15 |
| E2  | .145     | .201 | 3.68        | 5.10  |
| E3  | .039     | .075 | 1.00        | 1.90  |
| E4  | .487     | .529 | 12.38       | 13.43 |
| e   | .214 BSC |      | 5.44 BSC    |       |
| N   | 3        |      | 3           |       |
| L   | .780     | .800 | 19.81       | 20.32 |
| L1  | .161     | .173 | 4.10        | 4.40  |
| ØP  | .138     | .144 | 3.51        | 3.65  |
| Q   | .216     | .236 | 5.49        | 6.00  |
| S   | .238     | .248 | 6.04        | 6.30  |
| T   | 9°       | 11°  | 9°          | 11°   |
| U   | 9°       | 11°  | 9°          | 11°   |
| V   | 2°       | 8°   | 2°          | 8°    |
| W   | 2°       | 8°   | 2°          | 8°    |

## Recommended Solder Pad Layout

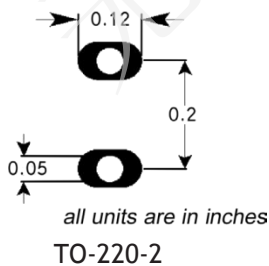

| Part Number | Package  | Marking    |
|-------------|----------|------------|
| GC3D20065A  | TO-220-2 | GC3D20065A |

**Diode Model (Per Leg)**

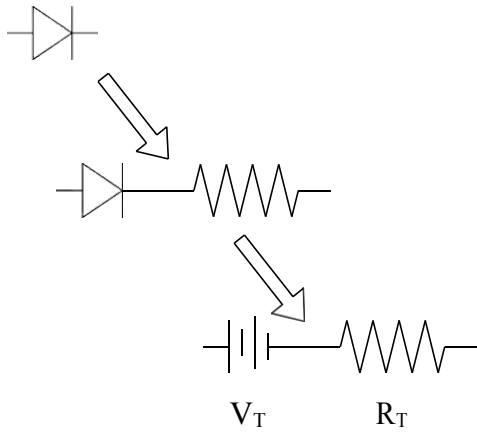

$$V_{fT} = V_T + I_f * R_T$$

$$V_T = 0.94 + (T_J * -1.3 * 10^{-3})$$

$$R_T = 0.044 + (T_J * 4.4 * 10^{-4})$$

Note:  $T_J$  = Diode Junction Temperature In Degrees Celsius, valid from 25°C to 175°C